



**MODEL FA1 "Mini"
Air Filtration System**

Operations Manual

READ AND SAVE THESE INSTRUCTIONS

WARNING:



Disconnect from power supply before performing maintenance procedures such as cabinet cleaning, changing filters or servicing of electric motor or other electric components

WARNING:



To reduce the risk of fire or electric shock, do not use this fan with any solid-state speed control device.

WARNING:



For general ventilating use only. Do not use to exhaust hazardous or explosive materials or vapors.

CAUTION:

Do not operate without having all filters in place.



Do not operate any fan with a damaged cord or plug. Discard fan or return to an authorized service facility for examination and/or repair.

Do not run cord under carpeting. Do not cover cord with throw rugs, runners or similar coverings. Arrange cord away from traffic area and where it will not be tripped over.

GETTING STARTED

Initial set-up

1. Open all cartons & locate Inlet, hose, hose clamps and wheels.
2. Remove ALL filters & packing materials from cartons and inside the FA1 “Mini” cabinet
3. Place the FA1 “Mini” on its side & install wheels or isolators in bottom plate
4. Install the inlet to the top of the lid
5. Remove plastic wrap from gas filter (Part # FA101D)
6. Carefully remove perforated cardboard from top and bottom of filter to expose “Green” filter media
7. Place gas filter (Part # FA101D) into bottom of cabinet – note direction of airflow arrow
8. Place HEPA filter (Part # FA100-2) on top of gas/odor filter– note airflow arrow
9. Place pleated panel filter (Part # FA102) on top of HEPA filter – note airflow arrow
10. Place polyester–pre-filter (Part # FA103) on top of panel filter
11. Close and latch lid
12. Attach power cord – rear of cabinet

Locating the air cleaner:

Placing the FA1 “Mini” as close as possible to the pollution source reduces the amount of hose or duct required, reduces back-pressure, lowers power consumption and improves overall performance.

Inlet hose attachment:

The FA1 “Mini” ships standard with a 1 x 2”, 1 x 3” or 2 x 2” inlet place the flex hose over the metal air inlet tube and tighten securely with the stainless steel clamp.

Connect the hose to a Fumex suction hood or place as close as possible to the pollution source.

Electric power

The FA1 “Mini” is manufactured with a universal blower/motor assembly (90-250/1/50-60). Default power cord/plug is US (120v). Contact Fumex for additional information or options.

Confirm that correct power supply is available.

CONTROLS

On/Off Switch

Simple one touch controls – Green light indicating blower speed will confirm power to the unit.

Blower/Fan

The FA1”Mini” utilizes a variable speed blower with three speed settings. Press the fan button to adjust speed control. Green light will indicate current speed. A flashing green light indicates a blower failure. To reset thermal protection disconnect unit from power source and restart. If light continues to flash contact Fumex Inc. for replacement information.

Filter monitoring

The FA1”Mini” utilizes a pressure differential switch to monitor the status of the particulate filters (3). “Change Filter” light will flash when filter(s) need to be replaced. The system monitors across all particulate filters concurrently. We recommend first changing the polyester pre-filter (FA103) and/or the panel filter (FA102) if light continues to flash then change the HEPA filter (FA100-2).

The FA1 “Mini” contains a VOC indicator to monitor odors/gases in the exhaust stream. When the gas filter becomes saturated (breakthrough occurs) the “Change Gas Filter” warning light will flash. (At initial start-up or when power is disconnected the “Change Gas Filter” light will blink for a short period of time as the voc sensor calibrates.)

GENERAL FILTER CARE

Fumex FA1”Mini” air filtration systems feature a multi-stage filtration system designed to remove a wide range of pollutants from a process plume in an extremely efficient, cost-effective manner. The system utilizes a pressure differential switch to indicate a blocked / clogged filter. Once the warning light flashes, filters should be inspected and clogged filters replaced.

STANDARD FILTERS :

Part # FA103 – Polyester pre-filter

The disposable polyester pre-filter is the first stage of the filtration process. Its main function is to remove dust particles 100 μ and larger in advance of the more expensive pleated panel filter.

Replacement:

The service life of the polyester pre-filter is determined by the type and volume of large particles collected.

Average service life is 4-6 weeks

Part # FA102 – Pleated Panel Filter

Pleated panel filters are merv 11 efficiency for use in removing particles as small as 10 μ from the pollution stream. Particles of this size are respirable and can cause respiratory problems in concentrations exceeding OSHA mandated levels.

Replacement:

A pleated panels’ service life is determined by the volume of particles remaining in the air stream after passing through the polyester pre-filter. When properly protected by the pre-filter, and depending on loading, pleated panel filters service life is 4-6 weeks.

Part # FA100-2 – HEPA Filter

The HEPA filter is 99.97% efficient in removing particles as small as 0.3 μ from an airstream. Particles of this size are respirable and can cause significant respiratory problems.

Replacement:

A HEPA's service life is determined by the volume of sub-micron particles remaining in the airstream after passing through the panel filter. When properly protected, and depending on loading, HEPA filters often provide months of service. Average service life is 2-4 months.

Part # FA101D – Gas/Odor Filter

Most process plumes contain several gases, some odorous – some not, some toxic at elevated concentrations – some completely harmless regardless of concentration. To ensure employee safety the type and concentration of pollutants must be determined. Please contact Fumex Engineering for selection assistance.

The FA1 "Mini" utilizes a blended activated carbon and activated alumina impregnated with KMnO₄ filter to capture and treat gases/odors. This combination of materials provides protection across a broad range of gases commonly found in industrial manufacturing processes.

Replacement:

The life of the gas/odor filter is highly dependent on the type and quantity of gases extracted from the process. Average service life is 4-6 months.

GENERAL MAINTENANCE

- 1) The blower motor is a sealed unit, 24,000 hr. MTBF rated. It is permanently lubricated and does not require oiling – keep it free of dust accumulations to prevent overheating.
- 2) Remove any loose accumulations of dust/debris from the air filter chamber periodically.

"This product employs overload protection (fuse). A blown fuse indicates a potential overload or short-circuit situation. If the fuse blows, unplug the product from the outlet. Replace the fuse as per the user servicing instructions (follow product marking for proper fuse rating) and check the product. If the replacement fuse blows, a short circuit may be present and the product should be discarded or returned to an authorized service facility for examination and/or repair"

Remote Start/Stop (Optional)

The FA1 "Mini" can be supplied with an optional remote start feature – Part# FA228. If this option is factory installed on your unit, simply provide 24v to the red wire and the black wire is "common". The unit will start when the signal is applied and turn-off when signal is removed.

WARNING

"Connect Remote Starter Cable to 24v, Class 2 Power Supply Only"



WARNING

"Disconnect From All Power Supplies Before Servicing"

R e p l a c e m e n t P a r t s

| Part # | Item | Part # | Item |
|---------|-----------------------------------|---------|--|
| | Cabinetry | | Electrical |
| FA108 | Wheels, standard | FAAU500 | Universal Blower motor Assembly - 90-250/1/50-60 |
| FA109 | Vibration Isolators | | |
| FA117 | Cabinet latch | FA003 | Control board assembly |
| FA118 | Cabinet hinge | FA114 | Fuse, 10 amp (120vac) |
| FA106A | Flanged air inlet 1 x 3" diameter | FA114A | Fuse, 15 amp (240vac) |
| FA106C | Flanged air inlet 1 x 2" diameter | FA115 | Cordset (120vac) |
| FA106B | Flanged inlet 2 x 2" diameter | FA115B | Cordset (230vac) |
| | | FA113 | Fuseholder |
| | Filters | | Gas / Odor Filters |
| FA100-2 | HEPA filter | FA101D | Blended carbon media |
| FA102 | Pleated panel filter | | |
| FA103 | Polyester pre-filter | | |
| | | | |

W a r r a n t y a n d L i a b i l i t y l i m i t a t i o n s :

Fumex FA1 mini air cleaners are guaranteed for 24 months from date of invoice to be electrically and mechanically sound. This warranty covers the material and workmanship only. Any defective item will be repaired or replaced, at our option, free of charge provided it has not been misused, abused, or otherwise damaged and is returned PREPAID to:

Fumex, Inc. 1150 Cobb International Pl., Kennesaw, GA 30152

There are no warranties which extend beyond the descriptions set forth in this warranty, notwithstanding any knowledge of Fumex, Inc. regarding the use or uses intended to be made of goods, proposed changes or additions to goods, or any assistance or suggestions that may have been made by Fumex personnel. Customer is responsible for determining the suitability of Fumex products for customer's use or resale, or for incorporating them into objects or applications which customer designs, assembles, constructs or manufactures.

Fumex reserves the right to discontinue any item and to make changes in the specifications, terms and conditions or prices at any time without prior notice. Information furnished in the specifications is believed to be accurate and reliable at time of printing, however Fumex accepts no responsibility for product use, or the effect of future design or specification changes.

For Assistance or Technical Support please Contact Fumex Inc.

phone 770-514-7907

fax 770-514-1547

USA toll-free 800-432-7550

www.fumexinc.com

Fumex, Inc.
1150 Cobb International Place
Kennesaw, GA USA 30152

© Fumex, Inc., 2017, all rights reserved.
Specifications subject to change without notice

FA1 MINI UNIT

90-250/1/50-60

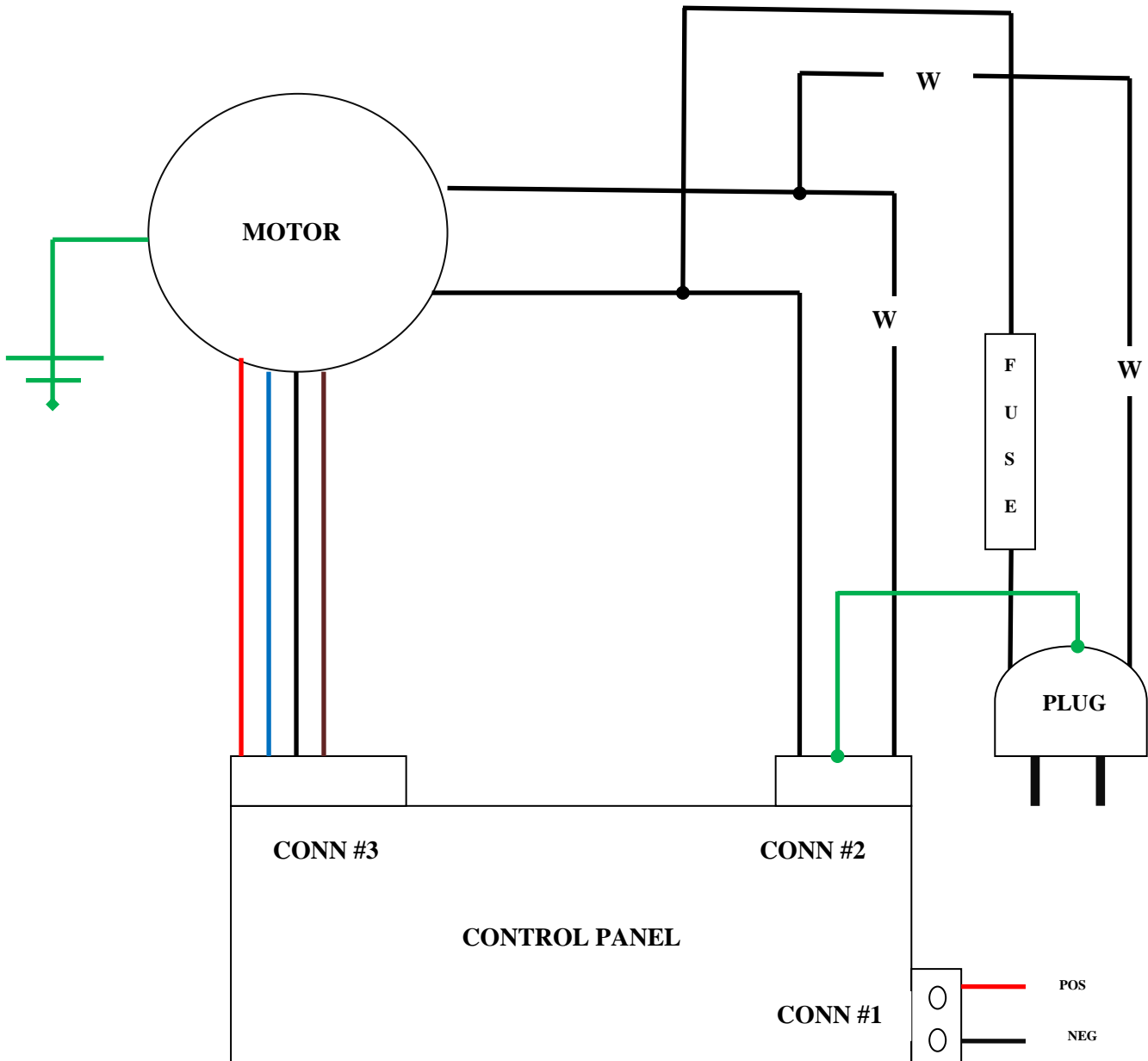

| LEGEND | |
|--------|-----------------------|
| W | WHITE |
| 1 | REMOTE START CONECTOR |
| 2 | THREE PIN CONNECTOR |
| 3 | FIVE PIN CONNECTOR |

RELAY ACTIVATION PROCEDURES FOR FA1 UNITS

1. Remove all power sources from FA1 unit
2. Locate eight screws securing cabinet bottom panel
3. Remove all and gently pry bottom panel loose

CAUTION

Do not work on panel with power applied

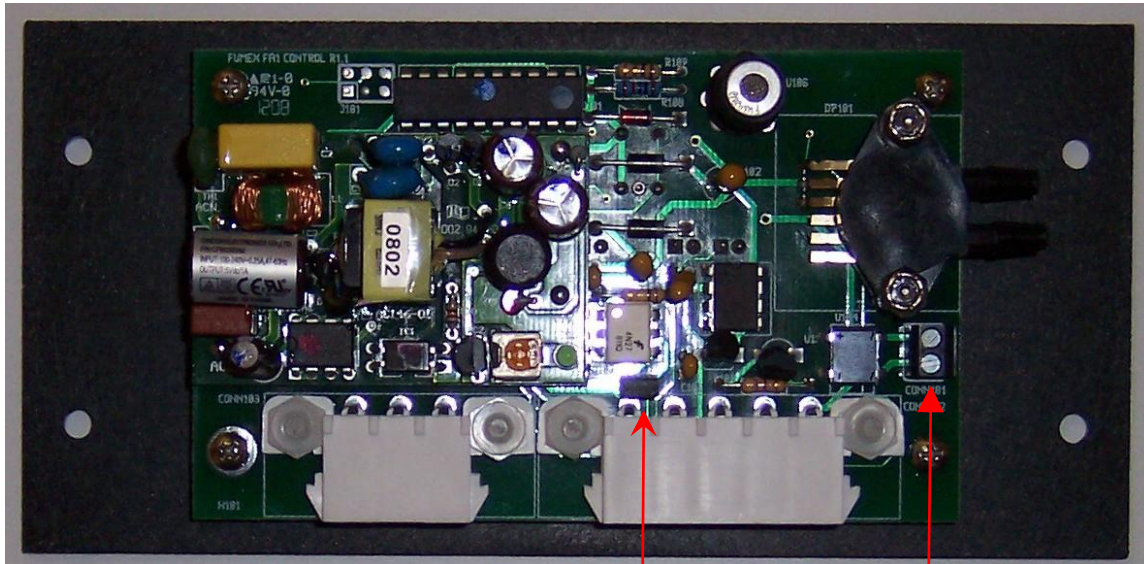

Relay activation jumper

24 volt start connector

4. Locate relay activation Jumper on rear of control panel. (Small plastic rectangle)
5. Gently remove jumper by pulling cap off pins. Shorting cap should be installed over a single pin for storage and to prevent loss of cap.

Once the jumper has been removed the unit will only start by applying the proper voltage to the start stop relay. When the unit is running the on and off switch can be used as long as start relay has power.

6. Reinstall bottom panel and screws
7. Apply power to start relay (see wiring diagram for your unit)

RELAY DE-ACTIVATION

1. Disconnect all power sources to FA1 unit.
2. Locate and remove eight screws securing the bottom panel
3. Remove all eight screws and gently pry bottom panel loose

CAUTION

Do not work on panel with power applied

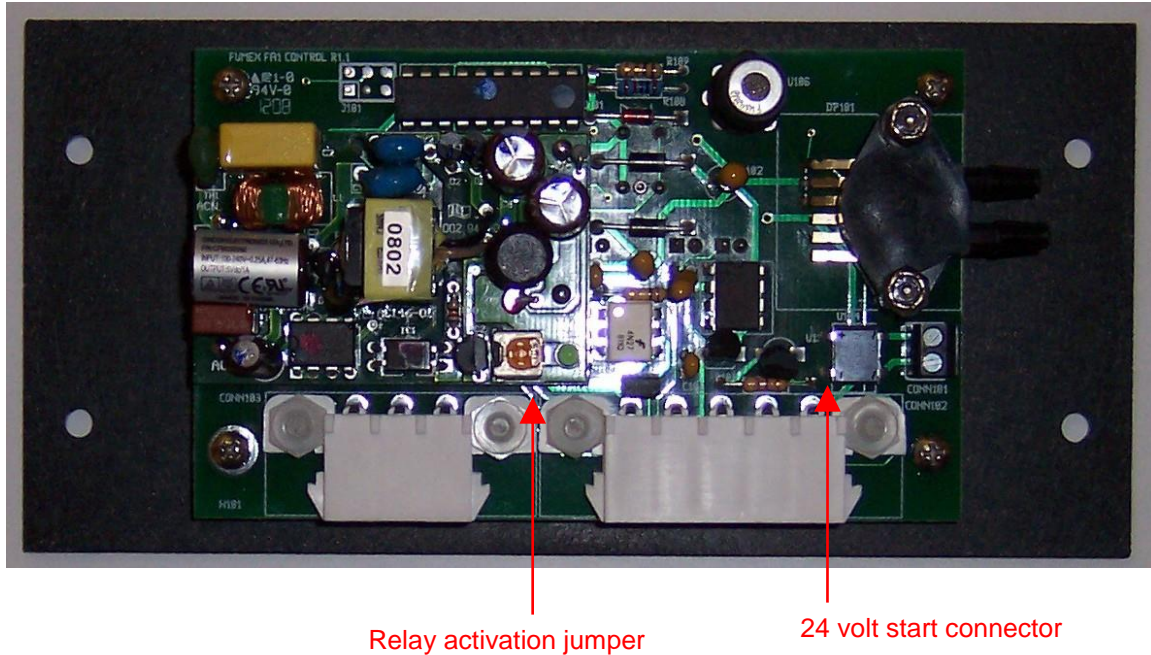

4. Locate relay activation Jumper on rear of control panel. (Small plastic rectangle)
5. Gently install jumper by pushing cap over pins.

Once the jumper has been installed the unit will can only be started by using the control panel. All relays will become non-functional.

6. Reinstall control panel and screws
7. Apply power to unit
8. Start Unit