



**MODEL FA5-1**  
**Air Filtration System**

**Operations Manual**

**READ AND SAVE THESE INSTRUCTIONS**

**WARNING:**



Disconnect from power supply before performing maintenance procedures such as cabinet cleaning, changing filters or servicing of electric motor or other electric components

**WARNING:**



To reduce the risk of fire or electric shock, do not use this fan with any solid-state speed control device.

**WARNING:**



For general ventilating use only. Do not use to exhaust hazardous or explosive materials or vapors.

**CAUTION:**

Do not operate without having all filters in place.



Do not operate any fan with a damaged cord or plug. Discard fan or return to an authorized service facility for examination and/or repair.

Do not run cord under carpeting. Do not cover cord with throw rugs, runners or similar coverings. Arrange cord away from traffic area and where it will not be tripped over.

# GETTING STARTED

## Initial set-up

1. Remove the FA5-1 unit from the packaging and locate and open the accessory box.
2. Open the FA5-1 cabinet and remove the protective packaging from the gas/odor filter(s) (part# FA501D). Replace the filter into the cabinet noting the airflow direction arrow should point up.
3. The HEPA filter (Part# FA500) and Pre-filter (Part# FA540B) are preinstalled - simply verify the filters are in position.
4. Close and latch the front door.

## Locating the air cleaner:

Placing the FA5-1 as close as possible to the pollution source reduces the amount of hose or duct needed, reduces back-pressure, lowers power consumption and improves overall performance. Wheels are standard equipment on the FA5-1, but rubber isolators are available if the unit is to be placed permanently in position. If you prefer isolators, call 800-432-7550 to arrange a no-charge exchange.

## Inlet hose attachment:

Install the air inlet flange (labeled) to the air inlet port located at the back bottom of the FA5-1 cabinet. Secure the port with the screws provided. Attach the hose to the inlet. Connect the hose to a Fumex suction hood or place as close as possible to the pollution source.

## Electric power:

Locate the Fumex nameplate located on back of cabinet to determine the power supply necessary. The FA5-1 is factory configured for 90-120/1/50-60 or 220-250/1/50-60. Please contact Fumex Inc. with any questions/concerns in regards to power supply.

## Filter Setting / Calibrations:

To maximize filter life – Connect the FA5 to the process (including cabinets, shrouds/hoods and hoses) and follow the filter calibration procedure attached.

# CONTROLS

## On/Off Switch

Simple on/off power button located on front display - green light indicates power to the unit.

## Blower/Fan

The FA5-1 utilizes a variable speed blower with 10 speed settings. Press the up /down arrows to increase and decrease the blower speed. Blower gradually increases in speed as arrow is pressed - some slight delay is normal operation. Speed is indicated by the bar graph located above blower label. A green light will indicate that the blower is operating – no light indicates a blower failure.

## Filter monitoring

The FA5-1 utilizes independent pressure modules to monitor the status of each particulate filter (the pre-filter and the HEPA filter). Filter status is indicated by the corresponding bar graph (“pre” for part# FA540B; “HEPA” for part# FA500). The bar graph will increase in 25% increments until the filter is “loaded”. Amber lights will indicate that a filter change is necessary.

The FA5-1 contains a VOC indicator to detect odors/gases in the exhaust stream. The system continually monitors the exhaust stream and indicates on the bar graph labeled “cell”. When breakthrough is detected the amber light will illuminate indicating a filter change is necessary.

# GENERAL FILTER CARE

Fumex FA5-1 air purifiers feature a multi-stage filtration system designed to remove a wide range of pollutants from the process plume in an extremely efficient, cost-effective manner.

## **STANDARD FILTERS:**

### Part # FA540B – Pre-filter Assembly

The pre-filter assembly is the first stage in the filtration process. Unique design minimizes operator/maintenance personnel exposure to contaminants.

#### *Replacement:*

Filter life is highly dependent on the amount and size of the captured particulates. Average service life is 4-6 months.

### Part # FA500 – HEPA Filter

The HEPA filter is 99.97% efficient in removing particles as small as 0.3 $\mu$  from an airstream. Particles of this size are respirable and can cause significant respiratory problems.

#### *Replacement:*

A HEPA's service life is determined by the volume of sub-micron particles remaining in the airstream after passing through the pre-filters. When properly protected, and depending on loading, HEPA filters often provide months of service. Average service life is 6-8 months.

### Part # FA501D – Gas/Odor Filter (CELL)

Most process plumes contain several gases, some odorous – some not, some toxic at elevated concentrations – some completely harmless regardless of concentration. To ensure employee safety the

type and concentration of pollutants must be determined. Please contact Fumex Engineering for selection assistance.

The FA5-1 utilizes a blended activated carbon and activated alumina impregnated with KMnO<sub>4</sub> filter to capture and treat gases/odors. This combination of materials provides protection across a broad range of gases commonly found in industrial manufacturing processes.

***Replacement:***

The gas/odor filter (“cell”) life is dependent on the concentrations and characteristics of the gases generated in the process. The FA5-1 monitors the effectiveness of the filter with an integrated electronic VOC sensor that will indicate with an amber light when “breakthrough” is detected. Some gases have very low odor thresholds and will become a nuisance prior to filter saturation indicator and can be changed accordingly.

## **GENERAL MAINTENANCE**

- 1) The blower motor(s) is a sealed unit, 24,000 hr. MTBF rated. It is permanently lubricated and does not require oiling – keep it free of dust accumulations to prevent overheating.
- 2) Remove any loose accumulations of dust/debris from the air filter chamber periodically.

“This product employs overload protection (fuse). A blown fuse indicates an overload or short-circuit situation. If the fuse blows, unplug the product from the outlet. Replace the fuse as per the user servicing instructions (follow product marking for proper fuse rating) and check the product. If the replacement fuse blows, a short circuit may be present and the product should be discarded or returned to an authorized service facility for examination and/or repair”

## **Remote Interface/Connectivity**

The FA5-1 can be supplied with an optional interface package providing remote start/stop and filter monitoring capabilities. Please see below for instructions.

<b>R e p l a c e m e n t P a r t s</b>			
<b>Part #</b>	<b>Item</b>	<b>Part #</b>	<b>Item</b>
	<b>Cabinetry</b>		<b>Electrical</b>
FA508	Wheels, standard	FAAU1100	Blower motor assembly
FA509	Vibration Isolators		
FA517	Cabinet latch	FA501	Display board assembly
FA518	Cabinet hinge	FA502	Power board assembly
		FA514A	Fuse, 15 amp
FA506-3	Flanged air inlet nipple, 3"Ø	FA515	Cordset (120vac)
FA506-4	Flanged air inlet nipple, 4"Ø	FA515B	Cordset (230vac)
FA506-6	Flanged air inlet nipple, 6"Ø	FA513	Fuseholder
	<b>Filters</b>		<b>Gas / Odor Filters</b>
FA500	HEPA filter	FA501D	A/C + A/A cell w/ KMnO4
FA540B	Pre-Filter	FA501C	Activated carbon filter

## **Warranty and Liability limitations:**

Fumex FA5 air cleaners are guaranteed for 24 months from date of invoice to be electrically and mechanically sound. This warranty covers the material and workmanship only. Any defective item will be repaired or replaced, at our option, free of charge provided it has not been misused, abused, or otherwise damaged and is returned PREPAID to:

Fumex, Inc. 1150 Cobb International Pl., Kennesaw, GA 30152

There are no warranties which extend beyond the descriptions set forth in this warranty, notwithstanding any knowledge of Fumex, Inc. regarding the use or uses intended to be made of goods, proposed changes or additions to goods, or any assistance or suggestions that may have been made by Fumex personnel. Customer is responsible for determining the suitability of Fumex products for customer's use or resale, or for incorporating them into objects or applications which customer designs, assembles, constructs or manufactures.

Fumex reserves the right to discontinue any item and to make changes in the specifications, terms and conditions or prices at any time without prior notice. Information furnished in the specifications is believed to be accurate and reliable at time of printing, however Fumex accepts no responsibility for product use, or the effect of future design or specification changes.

***For Assistance or Technical Support please Contact Fumex Inc.***

phone 770-514-7907

fax 770-514-1547

USA toll-free 800-432-7550

[www.fumexinc.com](http://www.fumexinc.com)

Fumex, Inc.  
1150 Cobb International Place  
Kennesaw, GA USA 30152

© Fumex, Inc., 2017, all rights reserved.  
Specifications subject to change without notice



## FA5 Interface Package

1	BLACK	24 VOLT START OUT (NEG)
2	RED	24 VOLT START IN (POS)
3	BROWN	Gas/Odor WARNING SIGNAL
4	ORANGE	POWER FOR WARNING LIGHTS
5	YELLOW	HEPA WARNING SIGNAL
6	ORANGE	POWER FOR WARNING LIGHTS
7	ORANGE	POWER FOR WARNING LIGHTS
8	GREEN	PRE FILTER WARNING SIGNAL
9	WHITE	DRY CONTACT ( BLOWER)
10	BLUE	DRY CONTACT (BLOWER)

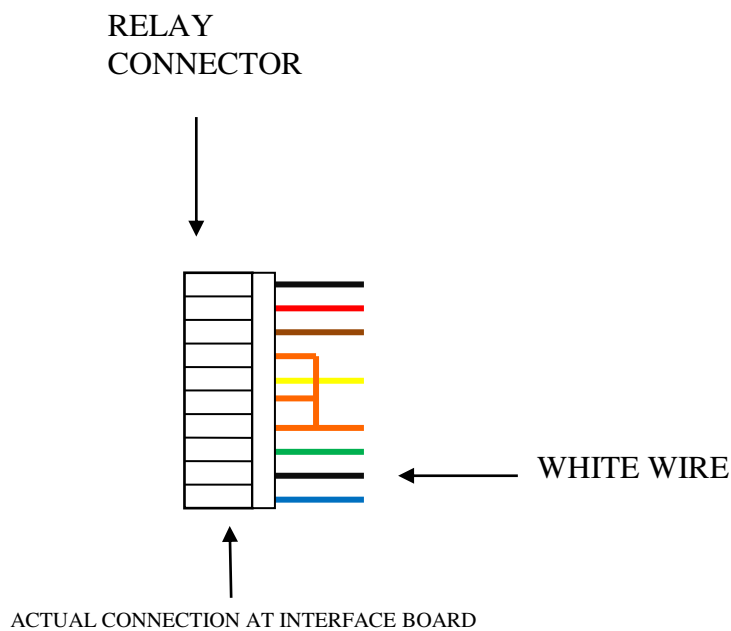

# **SYSTEM CALIBRATION**

## **ATTENTION**

**SYSTEM CALIBRATION REQUIRES A FULL SET OF NEW FILTERS AND UNIT MUST BE COMPLETELY INSTALLED**

1. CONNECT ELECTRICAL POWER WAIT FOR SELF TEST TO COMPLETE
2. TURN UNIT ON.
3. ONCE UNIT IS RUNNING LOWER SPEED UNTIL NO BARS ARE VISIBLE
  - A) PRESS AND HOLD THE BLOWER DOWN BUTTON THEN PRESS AND HOLD THE BLOWER UP BUTTON HOLD BOTH FOR 5 SECONDS.
  - B) THE UNIT WILL NOW START THE CALIBRATION CYCLE.
  - C) BLOWER SPEED WILL FLUCTUATE DURING CALIBRATION.
  - D) ONCE UNIT STOPS CYCLING YOU ARE FULLY CALIBRATED AND READY FOR USE.
  - E) GREEN BLOWER LIGHT WILL COME ON STEADY AFTER CALIBRATION IS COMPLETE.

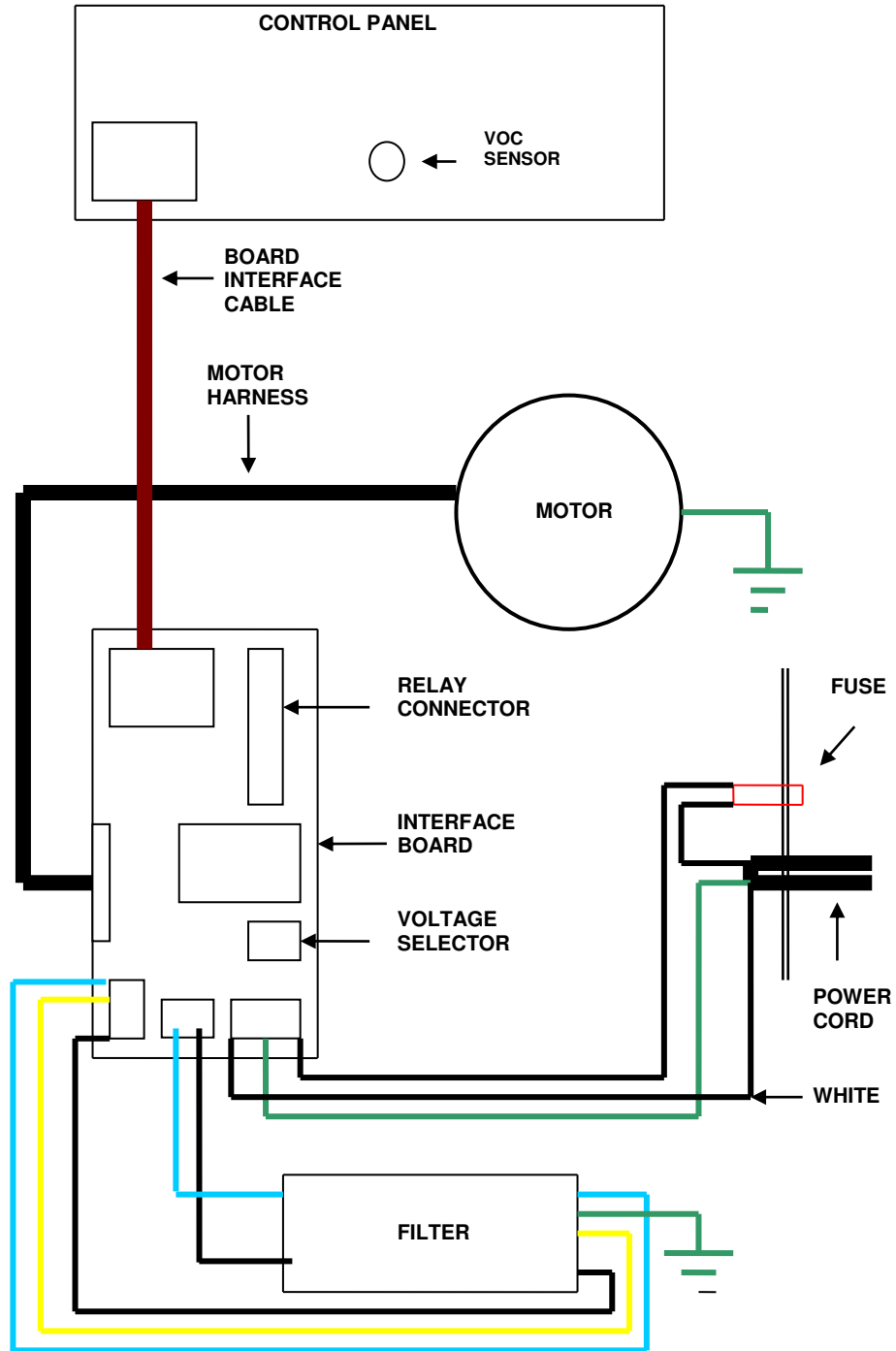



## INTERFACE ACTIVATION PROCEDURES FOR FA5 UNIT

1. Remove all power sources from FA5 unit
2. Locate six screws securing unit control panel
3. Remove all and gently pry Control panel loose six screws

### CAUTION

**Do not allow panel to hang from hoses or interface cable**



**Relay activation jumper**

**Relay activation jumper**

4. Locate relay activation Jumper on control panel. (Small plastic rectangle) There are two possible locations depending on which board revision you have
5. Gently remove jumper by pulling cap off pins. Shorting cap should be installed over a single pin for storage and to prevent loss of cap.

**Once the jumper has been removed the unit will only start by applying the proper voltage to the start stop relay. When the unit is running the on and off switch can be used as long relay has power.**

6. Reinstall control panel and screws
7. Apply power to start relay (see wiring diagram for your unit)