

The **Fumex FA1-E** industrial indoor air cleaner utilizes a high performance 3 stage hybrid air cleaning system to capture and treat air pollutants produced by many industrial processes. Easy to use digital controls and an integrated electronic gas sensor continuously monitor system performance and display operating parameters. A large capacity pre-filter protects the systems large HEPA filter providing an extremely cost-effective, efficient indoor air cleaning system. The FA1's filtration capacity and powerful, quiet variable speed blower provide maximum application flexibility. Ideal for a variety of light to medium duty air cleaning applications.

- Laser Cutting**
- Electronic Soldering**
- Laser Printing**
- 3D Printing**
- Mechanical Engineering**
- Dental Lab**
- Pharmaceutical & Medical**
- Beauty**
- And Many More**



CONSTRUCTION:

- Cabinet: 16 ga. welded steel, powder coat finish
- Baffled – sound attenuated
- Sound Level: 59 dbA
- Weight: 65 lbs.

BLOWERS:

- Performance: **165 cfm @ 19" wc**
- Variable speed blower
- Centrifugal - direct-drive, brushless motor
- Rated 20,000 hour + mtbf

ELECTRIC / CONTROLS:

- 90/250/1/50-60 (**120v or 240v plug**)
- Digital display with variable speed blower
- Pre-wired 3 wire power cable, 9 ft. with plug
- Digital Controls
 - Electronic variable speed blower control
 - High visibility LED filter indicator
- Calibrated electronic VOC gas sensor
- Electronic interface relay for filter monitoring
- Amp Draw: 6.0 (120v) / 4.0 (240v)

STANDARD EQUIPMENT:

- UL, ULC and CE/TUV compliance available
- 5 ft. 2-ply ribbed rubber hose
- **1 x 2", 1 x 3" or 2 x 2"** inlet dia. hose options w/clamps
- Digital graphic controls
- (4) Industrial grade wheels
- Installation guide / Operations manual

STANDARD FILTER SET:

- 5.5" - Pre-Filter:
 - Large capacity 85% efficient MERV 11 panel filter
 - Clean design limits operator exposure to particulates
- 2" - HEPA Filter:
 - 99.97% efficient @ 0.3 micron
- 2" - Gas / Odor Filter:
 - Large capacity gas / odor filter
 - Provides broad spectrum gas/odor control
 - Dustless construction suitable for all environments
 - Bonded carbon technology maximizes one pass efficiency
 - 100 % recyclable construction



MADE IN THE USA

FUMEX
1150 Cobb International Place
Kennesaw, GA 30152
800-432-7550 | 770-514-7907

ADDITIONAL TECHNICAL DATA

DIMENSIONS

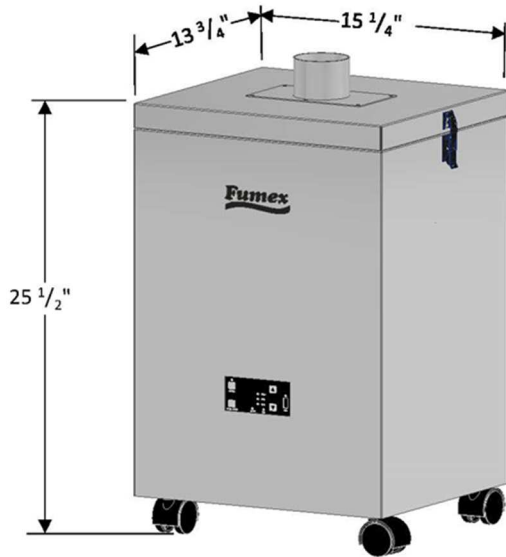

INLET OPTIONS

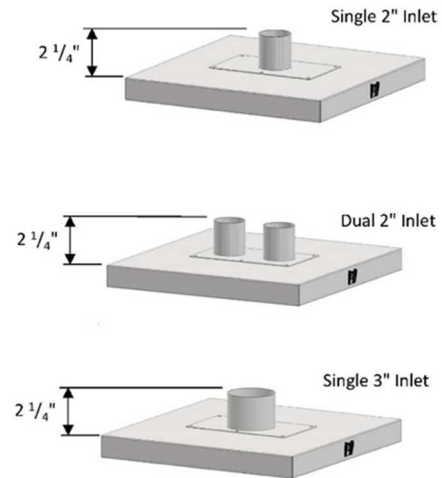

DIGITAL CONTROLS



• **OSHA compliant!**
Programmable via USB port
pressure set points,
blower speeds, and VOC
detection.

- **High visibility LED display** indicating blower speed, filter, and unit system status.
- **System Data logging:** monitoring blower usage, filter service intervals accessed by USB port

FUMEX FILTER SYSTEM

Pre-Filter (FA102B)
HEPA Filter (FA100)
Activated Carbon Filter (FA101D)

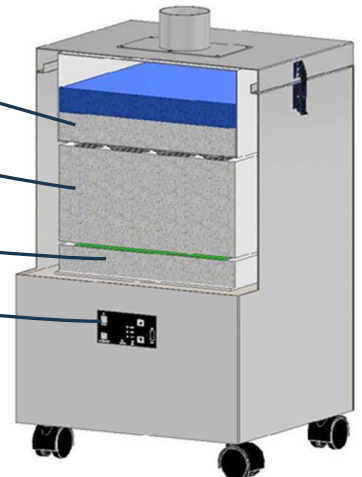

OPTIONAL CAPTURE ARMS & HOODS



SPECIALIZED APPLICATION ACCESSORIES

