

The Fumex FA1 industrial indoor air cleaner utilizes a high performance 3 stage hybrid air cleaning system to capture and treat air pollutants produced by many industrial processes. Easy to use digital controls and an integrated electronic gas sensor continuously monitor system performance and display operating parameters. A large capacity pre-filter protects the systems large HEPA filter providing an extremely cost-effective, efficient indoor air cleaning system. The FA1's filtration capacity and powerful, quiet variable speed blower provide maximum application flexibility. Ideal for a variety of light to medium duty air cleaning applications.



Laser



Electronics



Printing



3D Printing



Mechanical  
Engineering



Dental



Pharmaceutical  
& Medical



Beauty



Other



### Construction:

- Cabinet: 16 ga. welded steel, powder coat finish
- Baffled – sound attenuated
- Sound Level: 59 dbA
- Weight: 65 lbs.

### Blowers:

- Performance: 165 cfm @ 19" wc
- Variable speed blower
- Centrifugal - direct-drive, brushless motor
- Rated 20,000 hour + mtbf

### Electrics/Controls:

- 90/250/1/50-60 (120v or 240v plug)
- Digital display with variable speed blower
- Pre-wired 3 wire power cable, 9 ft. with plug
- Digital Controls
  - Electronic variable speed blower control
  - High visibility LED filter indicator
- Calibrated electronic VOC gas sensor
- Electronic digital interface relay for two-way communication, filter monitoring and remote start/stop control
- Amp draw to 6.0 (120v) or 4.0 (240v)

### Standard Equipment:

- UL, ULC and CE/TUV compliance available
- 5 ft. 2-ply ribbed rubber hose
- 1 x 2" inlet, 1 x 3" inlet or 2 x 2" inlet diameter hose with clamps
- Digital graphic controls
- (4) Industrial grade wheels
- Installation guide / Operations manual

### Standard Filter Set:

- 5.5" - Pre-Filter:
  - Large capacity 85% efficient MERV 11 panel filter
  - Clean design limits operator exposure to particulates
- 6" - HEPA Filter:
  - 99.97% efficient @ 0.3 micron
  - Large capacity mini-pleat construction
- 2" - Gas / Odor Filter:
  - Provides broad spectrum gas/odor control
  - Dustless construction suitable for all environments
  - Bonded carbon technology maximizes one pass efficiency
  - 100 % recyclable construction

# TECHNICAL DATA

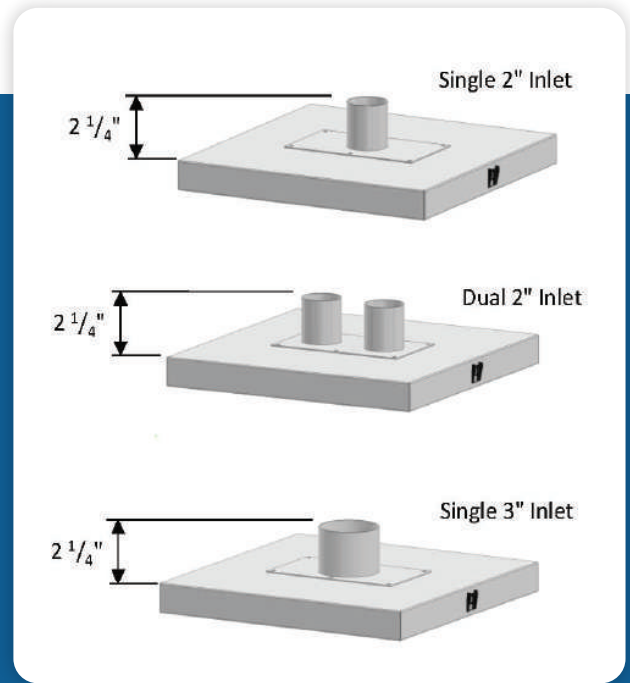
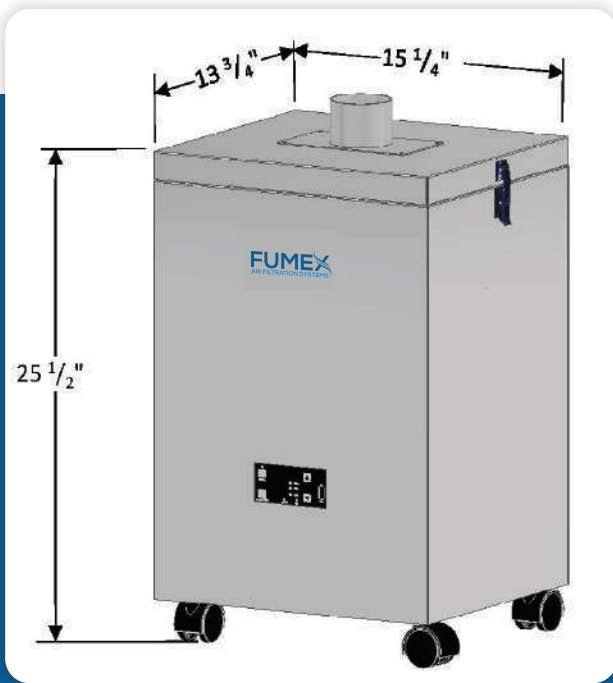

- ▶ Programmable via USB port pressure set points, blower speeds, and VOC detection
- ▶ High visibility LED display indicating blower speed, filter, and unit system status
- ▶ System Data logging: monitoring blower usage, filter service intervals accessed by USB port

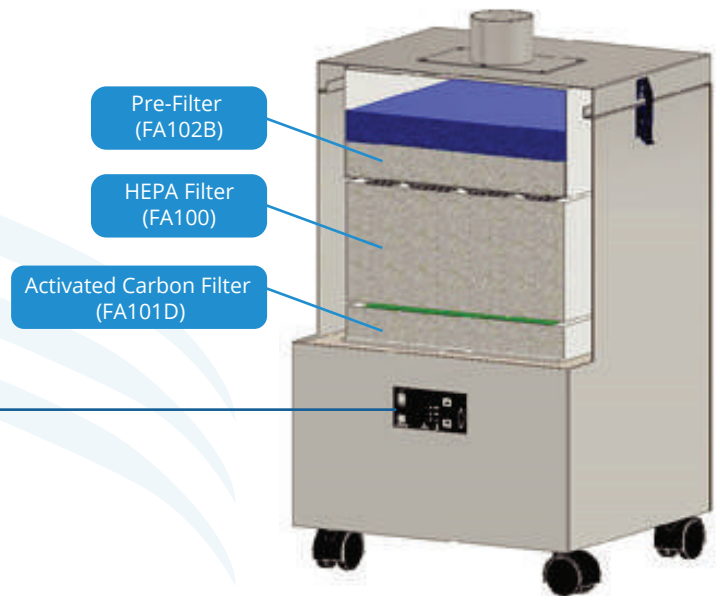
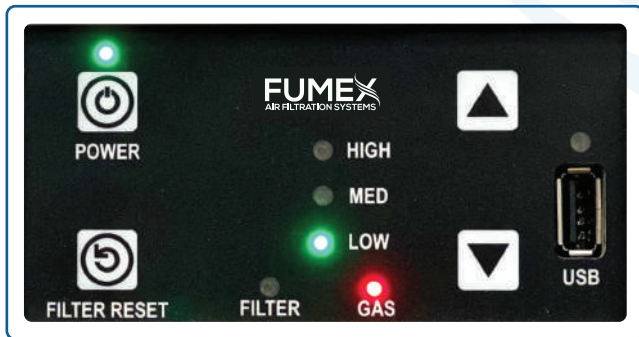

## Source Capture Arms and Hoods



## Additional Application Accessories



Terms: Net 30 days with approved credit  
 FOB POINT: Kennesaw (Atlanta), GA

FUMEX | 1150 Cobb International Place Kennesaw, GA 30152  
 770-514-7907 | 800-432-7550 (toll) | www.fumexinc.com

