

The Fumex FA2-E fume extractor utilizes a high performance 3 stage hybrid air filter system to capture and treat air pollutants generated during laser engraving processes. Operator friendly digital controls and integrated electronic gas sensor continuously monitor the system performance and display operating parameters on the high-visibility LED screen. Large capacity inexpensive pre-filters extend filter change intervals and protects the large HEPA filter and gas/odor filter offering an extremely cost-effective, efficient laser engraver fume extractor system. High performance variable speed blower provides maximum application flexibility. Ideal for medium to heavy duty laser engraving applications.



Laser



Electronics



Printing



3D Printing



Mechanical
Engineering



Dental



Pharmaceutical
& Medical



Beauty



Other



Construction:

- Cabinet: 304 grade Brushed stainless steel to IP56 compliance
- Baffled – sound attenuated
- Sound Level: 60 dbA
- Weight: 101 lbs. / 46 kg.

Blowers:

- Performance: 266 cfm @ 39" wc
- Variable speed blower
- Centrifugal - direct-drive, brushless motor
- Rated 20,000 hour + mtbf

Electrics/Controls:

- 90/250/1/50-60 (120v or 240v plug)
- Digital display with variable speed blower
- Pre-wired 3 wire power cable, 9 ft. with plug
- Digital Controls
- Electronic variable speed blower control
- Electronic individual filter monitoring with display
- Calibrated electronic VOC gas sensor
- Electronic digital interface relay for two-way communication, filter monitoring and remote start/stop control
- Amp draw to 12.0 (120v) or 8.0 (240v)

Standard Equipment:

- UL, ULC and CE/TUV compliance available
- 8 ft. 2-ply ribbed rubber hose
- 2", 3" or 4" inlet diameter hose with clamps
- Digital graphic controls
- (4) Industrial grade wheels – two locking
- Installation guide / Operations manual

Standard Filter Set:

- 10" - Pre-Filter:
 - o Large capacity box style
 - o 99% efficient @ 1.0 micron
 - o Deep-pleated dimpled media
- 6" - HEPA Filter:
 - o 99.97% efficient @ 0.3 micron
- 6" - Gas / Odor Filter:
 - o Large capacity gas/odor filter
 - o Provides broad spectrum gas/odor control
 - o Dustless construction suitable for all environments
 - o Bonded carbon technology maximizes one pass efficiency

TECHNICAL DATA

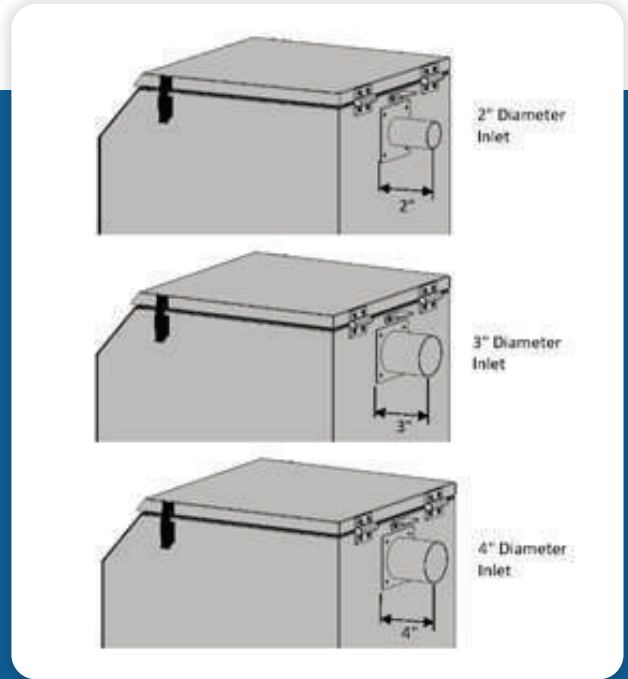
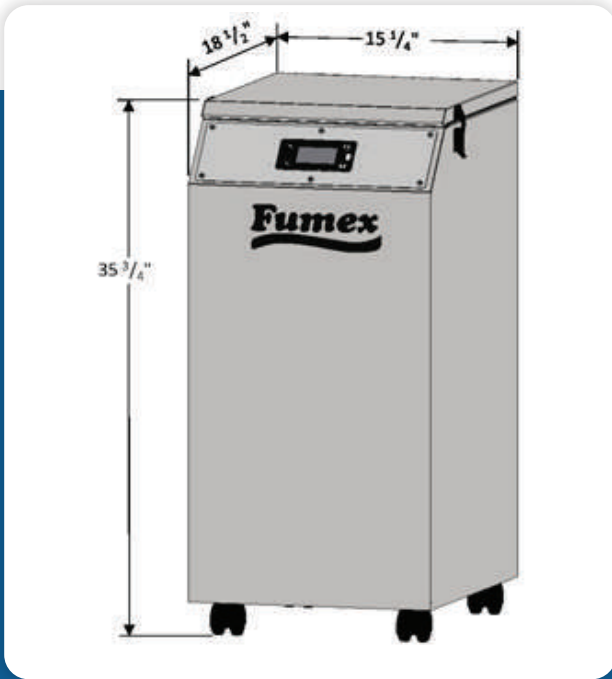

- ▶ Programmable via USB port pressure set points, blower speeds, and VOC detection
- ▶ High visibility Graphic display indicating blower speed, filter, and unit system status
- ▶ System Data logging: monitoring blower usage, filter service intervals accessed by USB port

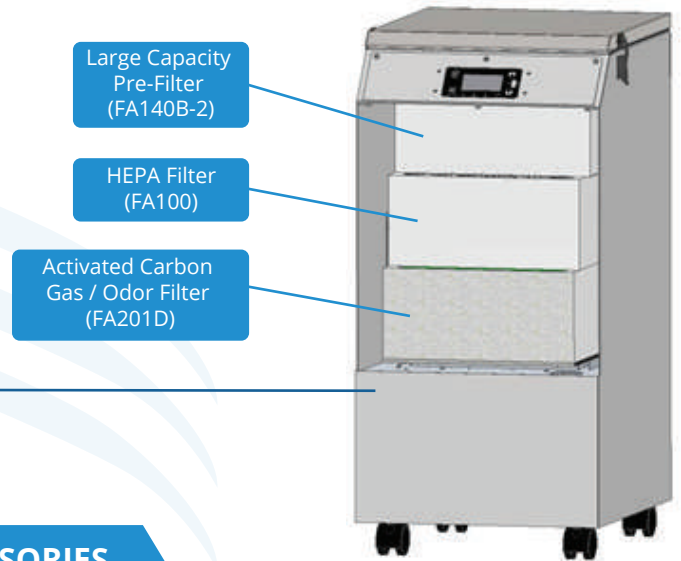

FUMEX ACCESSORIES

Source Capture Arms and Hoods



Additional Application Accessories

