

The GS3-200 Fumes Extractor manufactured by Fumex, utilizes a powerful high-performance blower, operator friendly digital controls, an integrated electronic gas sensor continuously monitor the system performance and display operating parameters on the high-visibility LED screen. and a large capacity filter, to effectively capture and eliminate plastic fumes, chemical fumes, odors, and gaseous contaminants. System can be fitted with a large variety of broad spectrum or chemical specific filters. Applications include inkjet fume removal, gluing stations, solvent fume removal, chemical baths, and laboratory use. Powerful, quiet fume extraction ideal for medium to heavy duty fume extracting applications.



Inkjet
Printing



Gluing
Stations



Laboratory



3D Printing



Copier |
Printing Rooms



Photography
Labs



Solvents



Chemical
Baths



Beauty |
Nail Salons



Construction:

- Cabinet: 304 grade Brushed stainless steel to IP56 compliance
- Baffled - sound attenuated
- Sound Level: 59 dbA
- Weight: 134 lbs. / 46 kg.

Blowers:

- Performance: 305 cfm @ 39" wc
- Variable speed blower
- Centrifugal - direct-drive, brushless motor
- Rated 20,000 hour + mtbf

Electrics/Controls:

- 90/250/1/50-60 (120v or 240v plug)
- Digital display with variable speed blower
- Pre-wired 3 wire power cable, 9 ft. with plug
- Digital Controls
- Electronic variable speed blower control
- Electronic filter monitoring with display
- Calibrated electronic VOC gas sensor
- Electronic digital interface relay for two-way communication, filter monitoring and remote start/stop control
- Amp Draw: 9.0 (120v) or 5.0 (240v)

Standard Equipment:

- UL, ULC and CE/TUV compliance available
- 8 ft. 2-ply ribbed rubber hose
- 3", 4" or 6" inlet diameter hose with clamps
- Digital graphic controls
- (4) Industrial grade wheels - two locking
- Installation guide / Operations manual

Standard Filter Set:

- 9" - Pre-Filter:
 - o Large capacity box style
 - o 99% efficient @ 1.0 micron
 - o Deep-pleated dimpled media
- 4" - High Odor / Gas Carbon Filters: (Qty needed 3)
 - o Large capacity filters with 90 lbs. of activated carbon
 - o Provides broad spectrum gas/odor control
 - o Dustless construction suitable for all environments
 - o Bonded carbon technology maximizes one pass efficiency

TECHNICAL DATA

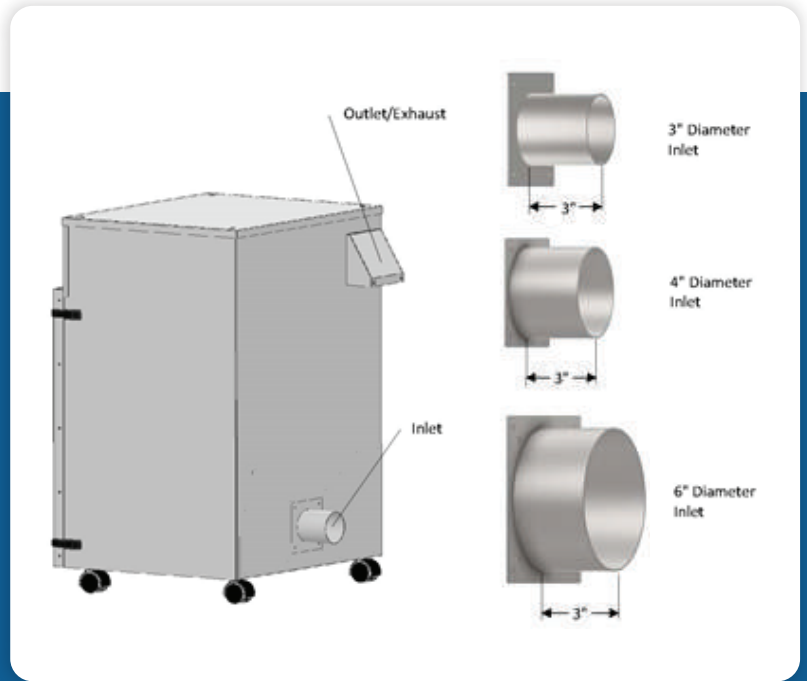
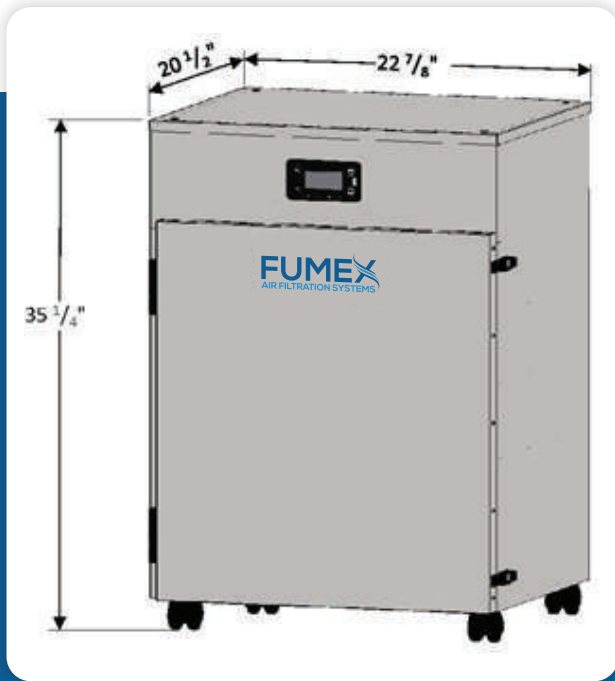

- Programmable via USB port pressure set points, blower speeds, and VOC detection
- High visibility Graphic display indicating blower speed, filter, and unit system status
- System Data logging: monitoring blower usage, filter service intervals accessed by USB port

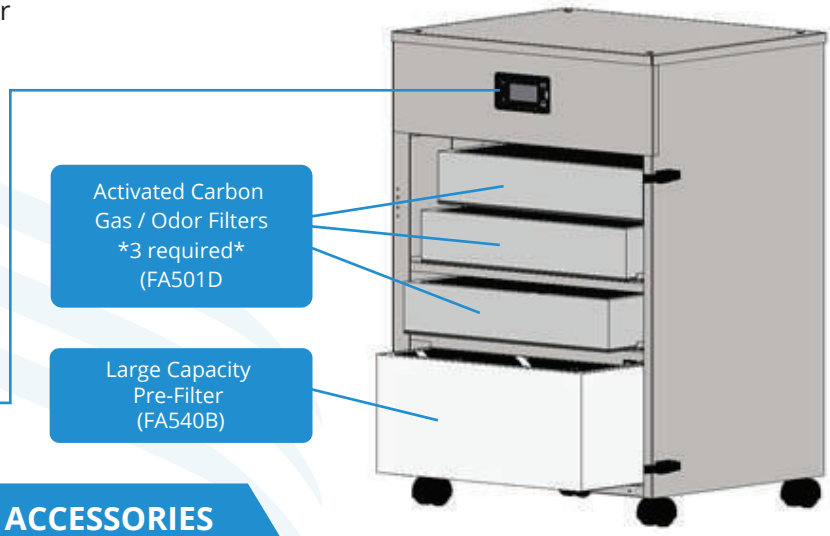

FUMEX ACCESSORIES

Source Capture Hoods

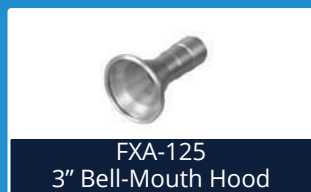

Source Capture Arms

