



## **FA5-1 Series Air Filtration System**

### **Operations Manual**

#### **READ AND SAVE THESE INSTRUCTIONS**

**WARNING:**



Disconnect from power supply before performing maintenance procedures such as cabinet cleaning, changing filters or servicing of electric motor or other electric components.

**WARNING:**



To reduce the risk of fire or electric shock, do not use this fan with any solid-state speed control device.

**WARNING:**



For general ventilating use only. Do not use to exhaust hazardous or explosive materials or vapors.

**WARNING:**



Use only a 15-Amp fuse.

**CAUTION:**



Do not operate without having all filters in place.

Do not operate any fan with a damaged cord or plug. Discard fan or return to an authorized service facility for examination and/or repair.

Do not run cord under carpeting. Do not cover cord with throw rugs, runners, or similar coverings. Arrange cord away from traffic area and where it will not be tripped over.

# **GETTING STARTED**

## **Initial set-up**

1. Remove the FA5-1 unit from the packaging and locate and open the accessory box.
2. Open the FA5-1 cabinet and remove the protective packaging from the FA501D gas/odor filter(s). Replace the filter into the cabinet noting the airflow direction arrow should point up.
3. The FA500 HEPA filter and FA540B Pre-filter are preinstalled - simply verify the filters are in position.
4. Close and latch the front door.

## **Locating the air cleaner**

Placing the FA5-1 as close as possible to the pollution source reduces the amount of ducting needed, reduces back-pressure, lowers power consumption, and improves overall performance. Placement should minimize hose length and the number of bends. Use capture hoods with high-efficiency entry whenever possible. The unit exhausts through the bottom panel make sure to allow for adequate ventilation.

## **Inlet hose attachment**

Install the air inlet flange (labeled) to the air inlet port located at the back bottom of the FA5-1 cabinet. Secure the port with the screws provided. Attach the hose to the inlet. Connect the hose to a Fumex suction hood or place as close as possible to the pollution source.

## **Electric power**

Locate the Fumex nameplate placed on the back of the cabinet to determine the power supply necessary. The FA5-1 is factory configured for 90-250/1/50-60 and must only use a 15-Amp Fuse. Please contact Fumex LLC. with any questions/concerns regarding power supply.

***Confirm that correct power supply is available.***

# CONTROLS

## **On/Off Switch**

Simple one touch controls – The green light above the POWER button will illuminate confirming power to the unit.

## **Blower/Fan**

The FA5-1 utilizes a variable speed blower with 8 speed settings. Press the up /down arrows to increase and decrease the blower speed. Blower gradually increases in speed as “Up” arrow is pressed - some slight delay is normal operation. Speed is indicated by the bar graph located above “BLOWER” label. A green light will indicate that the blower is operating – no light indicates a blower failure or loss of power.

## **Filter monitoring**

The FA5-1 utilizes independent pressure differential switches to monitor the status of each particulate filter (the Pre-filter and the HEPA filter). Filter status is indicated by the corresponding bar graph (“PRE” for part# FA540B; “HEPA” for part# FA500). The bar graph will increase in 20% increments until the filter is “loaded”. Red lights will indicate that a filter change is necessary. See Filter Reset Button instructions below.

The FA5-1 contains a VOC sensor to detect odors/gases in the exhaust stream. The system continually monitors the exhaust stream which is indicated on the bar graph labeled “GAS”. When the gas/odor filter becomes saturated, and breakthrough of the VOC occurs the “GAS” warning light will illuminate.

## **Filter Reset Button**

The *Filter Reset* button pops a menu on FA5-1 for the user to select which filter is being replaced. The menu is entered by holding the FILTER RESET button down for 750ms. The blower will stop, and the system will show a menu which allows the user to select which filter is being replaced or an ALL filter option for all filters to be replaced at once.

Once a filter to be replaced is selected, the user holds the FILTER RESET button again for 750ms to cause the system to reset the filter.

The filter tracking logic will create a new filter stack for the new filter stack configuration. The filter that is replaced is zeroed out and the filter number is incremented.

# **GENERAL FILTER CARE**

Fumex FA5-1 air purifiers feature a multi-stage filtration system designed to remove a wide range of pollutants from the process plume in an extremely efficient, and cost-effective manner. Once the warning lights illuminate, filters should be checked, and clogged filters replaced.

## **STANDARD FILTERS:**

### **Part # FA540B – Pre-filter Assembly**

The pre-filter assembly is the first stage in the filtration process. Unique design minimizes operator/maintenance personnel exposure to contaminants.

#### *Replacement:*

Filter life is highly dependent on the amount and size of the captured particulates. Average service life is 4-6 months.

### **Part # FA500 – HEPA Filter**

The HEPA filter is 99.97% efficient in removing particles as small as  $0.3\mu$  from an airstream. Particles of this size are respirable and can cause significant respiratory problems.

#### *Replacement:*

A HEPA's service life is determined by the volume of sub-micron particles remaining in the airstream after passing through the pre-filters. When properly protected, and depending on loading, HEPA filters often provide months of service. Average service life is 6-8 months.

### **Part # FA501D – Gas/Odor Filter**

Most process plumes contain several gases, some odorous – some not, some toxic at elevated concentrations – some completely harmless regardless of concentration. To ensure employee safety the type and concentration of pollutants must be determined. Please contact Fumex Engineering for filter selection assistance. These filters utilize a blended activated carbon and activated alumina impregnated with  $KMnO_4$  filter to capture and treat gases/odors. This combination of materials provides protection across a broad range of gases commonly found in industrial manufacturing processes.

# GENERAL MAINTENANCE

- 1) The blower motor(s) is a sealed unit, 24,000 hr. MTBF rated. It is permanently lubricated and does not require oiling – keep it free of dust accumulations to prevent overheating.
- 2) Remove any loose accumulations of dust/debris from the air filter chamber periodically.

“This product employs overload protection (fuse). A blown fuse indicates an overload or short-circuit situation. If the fuse blows, unplug the product from the receptacle. Replace the fuse as per the user servicing instructions (use only 15-Amp fuse) and check the product. If the replacement fuse blows, a short circuit may be present, and the product should be discarded or returned to an authorized service facility for examination and/or repair”.

## WARNING

“To Prevent the Risk of Electrical Shock, Connect Remote Interface Cable to 24v, Class 2 Power Supply Only”



## WARNING

“Disconnect from All Power Supplies Before Servicing”



# **Remote Interface and Connectivity Function**

The FA5-1 can be supplied with an optional interface package providing remote start/stop and filter monitoring capabilities (Part # FA227). Please see instructions below for Relay Activation/De-Activation procedures and refer to the drawing in Figure 1 for remote connections.

## **RELAY ACTIVATION PROCEDURES FOR FA5 UNITS**

1. To activate the relays so the remote feature can be used the software will need to be reprogrammed via a flash drive with a configuration file (*fumex.ini*) and the USB port on the control board. (Contact Fumex to acquire the correct configuration file for your unit).
2. Apply incoming power to the unit by connecting the power cord and turning the power switch located near the power cord on. Make sure the blower is not running and the green power light is off. This is called the “Soft On” state.
3. Reprogramming will lock out the Control Board power button. The ON/OFF function will only be able to be controlled remotely.
4. Copy the *fumex.ini* file onto a flash drive and make sure it is the only file on the flash drive. If anything else is on the flash drive the control board will not know which file to read.
5. Plug the flash drive with the desired *fumex.ini* file into the USB port on the front of the control board. (Make sure the unit is in the “Soft On” state before plugging in the flash drive.)
6. Initially the light above the USB port will be red. After the reprogramming is complete the light above the USB port will turn green and remain lit until the flash drive is removed from the USB port.
7. Remove the flash drive and apply 0-24 VDC to the start relay according to the wiring diagram in Figure 1 to start the unit.

Once the relays have been activated the unit will only start by applying the proper voltage to the start/stop relay.

## **RELAY DE-ACTIVATION PROCEDURES FOR FA5 UNITS**

1. To de-activate the relays so the remote feature cannot be used the software will need to be reprogrammed via a flash drive with a configuration file (*fumex.ini*) and the USB port on the control board. (Contact Fumex to acquire the correct configuration file for your unit).
2. Apply incoming power to the unit by connecting the power cord and turning the power switch located near the power cord on. Make sure the blower is not running and the green power light is off. This is called the “Soft On” state.
3. Reprogramming will unlock the Control Board power button. The ON/OFF function will now be able to be controlled at the unit.
4. Copy the *fumex.ini* file onto a flash drive and make sure it is the only file on the flash drive. If anything else is on the flash drive the control board will not know which file to read.
5. Plug the flash drive with the desired *fumex.ini* file into the USB port on the front of the control board. (Make sure the unit is in the “Soft On” state before plugging in the flash drive.)
6. Initially the light next to the USB port will be red. After the reprogramming is complete the light above the USB port will turn green and remain lit until the flash drive is removed from the USB port.
7. Remove the flash drive and start the unit as described in the “Controls” section.

Once the relays have been de-activated the unit will only start by using the front control panel. All relays will become non-functional.

NOTES  
 1. SW1 REMOTE SWITCH SHOULD ALWAYS BE IN "ON" POSITION

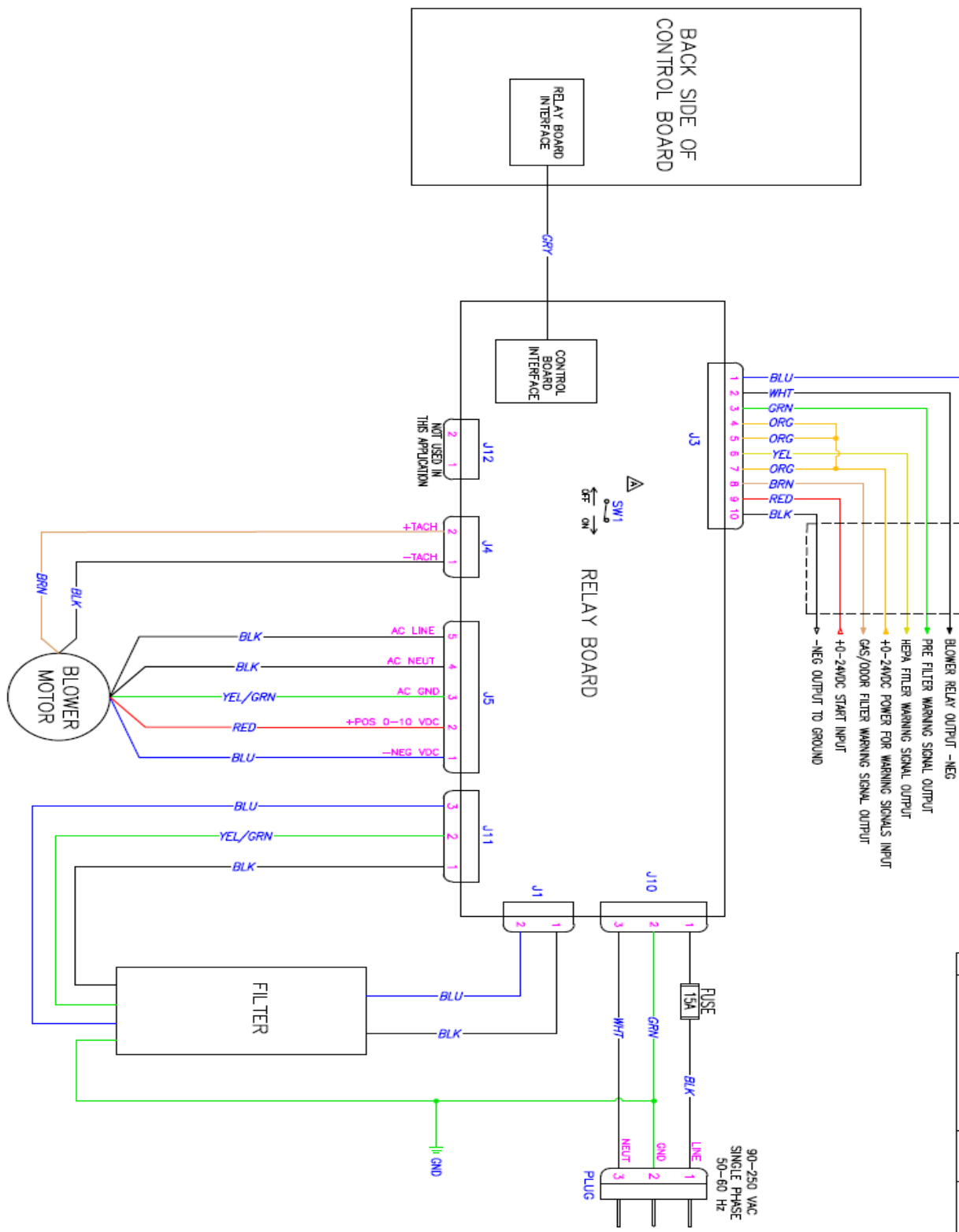

REV	DESCRIPTION	DATE	APPROVED
A	4800 09/15/2000	09/15/2000	JAC

		<b>FUMEX</b> <small>ENVIRONMENTAL TECHNOLOGIES</small>	
DESIGNED BY	DATE	REVISED BY	DATE
DRWING	09/15/2000	DRWING	09/15/2000
SCALE	1/1" = 1"	SCALE	1/1" = 1"
<b>FUMEX-1 &amp; CS3-200 WIRING SCHEMATIC</b>		<b>745-1 &amp; CS3-200 WIRING SCHEMATIC</b>	
TITLE	FORM NO.	DATE	REV.
A	20-428-00	09/15/2000	A

Figure 1

<b>R e p l a c e m e n t P a r t s</b>			
<b>Part #</b>	<b>Item</b>	<b>Part #</b>	<b>Item</b>
	<b>Cabinetry</b>		<b>Electrical</b>
FA508	Wheels, standard	FAAU1100	Blower motor assembly
FA509	Vibration Isolators	FA5005	Display board assembly
FA517	Cabinet latch	FA5006	Power board assembly
FA518	Cabinet hinge	FA513	Fuseholder
FA506-3	Flanged air inlet nipple, 3"Ø	FA514A	Fuse, 15 amp
FA506-4	Flanged air inlet nipple, 4"Ø	FA515	Cordset (120vac)
FA506-6	Flanged air inlet nipple, 6"Ø	FA515B	Cordset (240vac)
	<b>Filters</b>		<b>Gas/ Odor Filters</b>
FA500	HEPA filter	FA501D	A/C + A/A cell w/ KMnO4
FA540B	Pre-Filter		

Table 1

## **Warranty and Liability limitations:**

Fumex FA5 air cleaners are guaranteed for 24 months from date of invoice to be electrically and mechanically sound. This warranty covers the material and workmanship only. Any defective item will be repaired or replaced, at our option, free of charge provided it has not been misused, abused, or otherwise damaged and is returned PREPAID to:

Fumex, LLC. 1150 Cobb International Pl., Kennesaw, GA 30152

There are no warranties which extend beyond the descriptions set forth in this warranty, notwithstanding any knowledge of Fumex, LLC. regarding the use or uses intended to be made of goods, proposed changes or additions to goods, or any assistance or suggestions that may have been made by Fumex personnel. Customer is responsible for determining the suitability of Fumex products for customer's use or resale, or for incorporating them into objects or applications which customer designs, assembles, constructs, or manufactures.

Fumex reserves the right to discontinue any item and to make changes in the specifications, terms and conditions or prices at any time without prior notice. Information furnished in the specifications is believed to be accurate and reliable at time of printing, however Fumex accepts no responsibility for product use, or the effect of future design or specification changes.

***For Assistance or Technical Support please Contact Fumex LLC.***

phone 770-514-7907                      fax 770-514-1547  
 USA toll-free 800-432-7550  
[www.fumexinc.com](http://www.fumexinc.com)

**Fumex, LLC.  
 1150 Cobb International Place  
 Kennesaw, GA USA 30152**

© Fumex, LLC., 2021, all rights reserved.  
 Specifications subject to change without notice